

TA8415P

STEPPING MOTOR CONTROLLER / DRIVER

The TA8415P is general purpose unipolar stepping motor controller / driver, applicable to 3 / 4 phase motors and 1, 1-2, 2 phase excitation drive by initial setting of control terminals.

FEATURES

- 1 chip stepping motor controller / driver.
- 3 or 4 phase and 1, 1-2, 2 phase excitation drive are available.
- CW / CCW rotation and 1 clock or 2 clock drive are available.
- Hysteresis is provided with clock, CW / CCW, reset inputs for noise protection.
- Output enable, initial detect are available.
- Output current up to 400mA (MAX.)

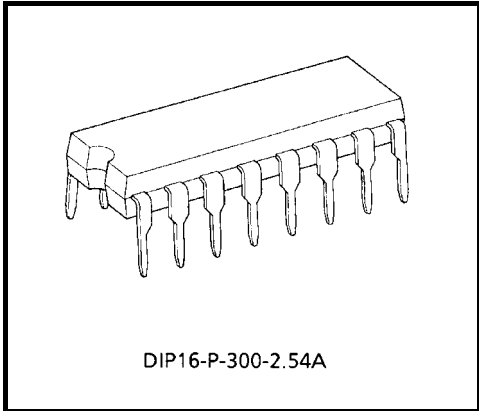

Weight: 1.11 g (Typ.)

BLOCK DIAGRAM

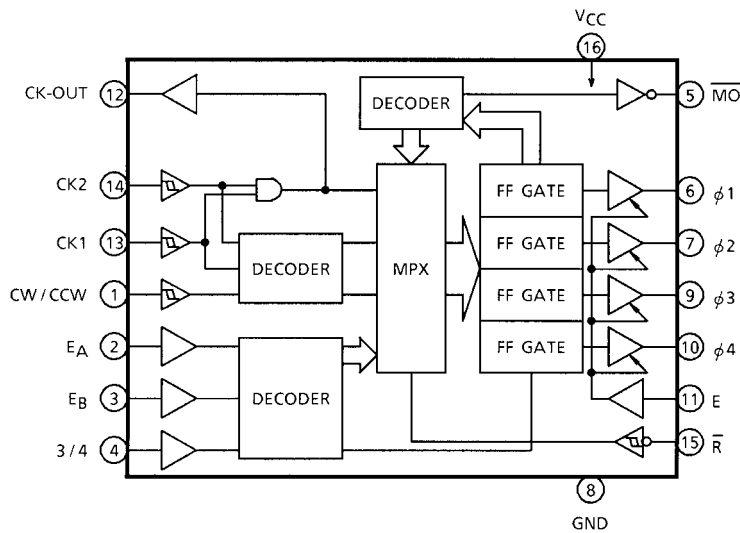

PIN FUNCTION

PIN No.	SYMBOL	PIN NAME	FUNCTIONAL DESCRIPTION	
1	CW / CCW	Clock Wise / Counter Clock Wise	Direction Control Input Function Table A	
2	E _A	Excitation A	Phase Excitation Mode Input	Truth Table B
3	E _B	Excitation B		
4	3 / 4	3 Phases / 4 Phases	Phase Control Input	
5	\overline{MO}	Monitor Out	\overline{MO} = "L" at Initial State	
6	$\phi 1$	$\phi 1$ Out	$\phi 1$ Output	
7	$\phi 2$	$\phi 2$ Out	$\phi 2$ Output	
8	GND	GND	GND	
9	$\phi 3$	$\phi 3$ Out	$\phi 3$ Output	
10	$\phi 4$	$\phi 4$ Out	$\phi 4$ Output	
11	E	Output Enable	Outputs are Enable at E = "H"	
12	CK-OUT	Clock-Out	Clock Output	
13	CK1	Clock I _n -1	Clock Input 1	Truth Table A
14	CK2	Clock I _n -2	Clock Input 2	
15	\overline{R}	Reset	Reset Input	
16	V _{CC}	V _{CC}	V _{CC}	

TRUTH TABLE A

CK1	CK2	CW / CCW	FUNCTION
	H	L	CW
	L	L	Inhibit
H		L	CCW
L		L	Inhibit
	H	H	CCW
	L	H	Inhibit
H		H	CW
L		H	Inhibit

TRUTH TABLE B

E _A	E _B	3 / 4 (Note)	FUNCTION	
L	L	L	4 Phases	1 Phase Excitation
H	L	L		2 Phase Excitation
L	H	L		1-2 Phase Excitation
H	H	L	Test Mode $\phi 1 \sim \phi 4$ ON	
L	L	H	3 Phases	1 Phase Excitation
H	L	H		2 Phase Excitation
L	H	H		1-2 Phase Excitation
H	H	H	Test Mode $\phi 1 \sim \phi 4$ ON	

Note: Conversion of Phase Excitation Mode must be made after the Reset Mode is established.

SCHEMATIC OF INPUTS AND OUTPUTS

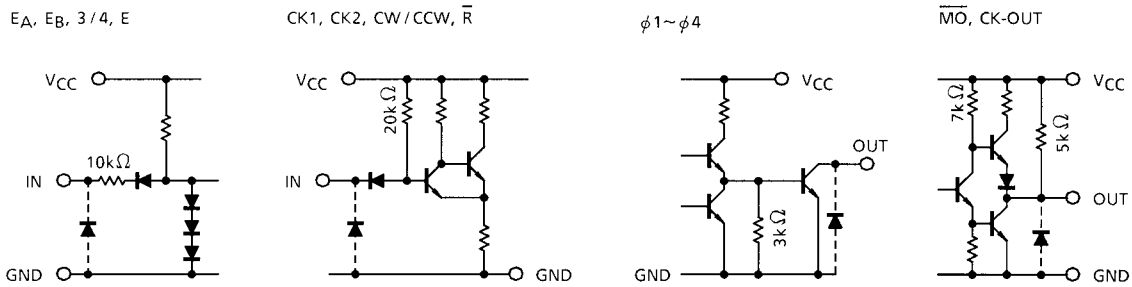

MAXIMUM RATINGS (Ta = 25°C Unless otherwise noted)

CHARACTERISTIC	SYMBOL	RATING	UNIT
Supply Voltage	V_{CC}	-0.3~7.0	V
Output Sustaining Voltage	$V_{CE(SUS)}\phi$	-0.3~28	V
Output Current (ϕn)	$I_{OUT\phi}$	400	mA
Output Current (MO, CK-OUT)	$I_{OUT\overline{MO}}$ I_{CK-OUT}	10	mA
Input Voltage	V_{IN}	-0.3~ $V_{CC} + 0.3$	V
Input Current	I_{IN}	± 1	mA
Power Dissipation	P_D	1.2	W
Operating Temperature	T_{opr}	-30~85	°C
Storage Temperature	T_{stg}	-55~150	°C

RECOMMENDED OPERATION CONDITION (Ta = -30~85°C)

CHARACTERISTIC	SYMBOL	TEST CONDITION	MIN	TYP.	MAX	UNIT
Supply Voltage	V_{CC}	—	4.5	5.0	5.5	V
Output Sustaining Voltage	$V_{CE(SUS)}\phi$	—	0	—	26	V
Output Current ϕn	"L" Level $I_{OUT\phi}$	—	—	—	200	mA
Output Current \overline{MO} , CK-OUT	"H" Level I_{OH}	—	—	—	-0.4	mA
	"L" Level I_{OL}	—	—	—	8	
Input Voltage	V_{IN}	—	0	—	V_{CC}	V
Clock Frequency	f_{CLOCK}	—	0	—	100	kHz
Power Dissipation	P_D	—	—	—	0.6	W

ELECTRICAL CHARACTERISTICS (Ta = 25°C)

CHARACTERISTIC		SYMBOL	TEST CIR-CUIT	TEST CONDITION	MIN	TYP.	MAX	UNIT	
Input Voltage	"H" Level	V_{IH}	—	—	2.0	—	—	V	
	"L" Level	V_{IL}		—	—	—	0.8		
Input Current	"H" Level	I_{IH}	—	$V_{CC} = 5.5 V, V_{IH} = 5.5 V$	—	—	10	μA	
	"L" Level	I_{IL}		$V_{CC} = 5.5 V, V_{IL} = 0.4 V$	—	—	-0.4	mA	
Hysteresis		ΔV_T	—	—	—	150	—	mV	
Supply Current		I_{CC}	—	—	—	—	100	mA	
Output Leakage Current ϕ_n		$I_{OH\phi}$	—	$V_{CC} = 5.5 V, V_{OUT} = 26 V$	—	—	100	μA	
Output Voltage	"H" Level	\overline{MO} CK-OUT	—	$V_{CC} = 4.5 V, I_{OH} = -0.4 mA$	2.4	—	—	V	
				$V_{CC} = 5.0 V, I_{OH} = -10 \mu A$	4.0	—	—		
	"L" Level	\overline{MO} CK-OUT	—	$V_{CC} = 4.5 V, I_{OL} = 8 mA$	—	—	0.4		
		ϕ_n		$V_{OUT\phi}$	$V_{CC} = 4.5 V, I_{OUT} = 400 mA$ $t = 100 ms$	—	—		1.1
					$V_{CC} = 4.5 V, I_{OUT} = 200 mA$ $t = 100 ms$	—	—		0.6

SWITCHING CHARACTERISTICS (Ta = 25°C)

CHARACTERISTIC		SYMBOL	TEST CIR-CUIT	TEST CONDITION	MIN	TYP.	MAX	UNIT
Propa- gation Delay Time	"H" Level	CK- ϕ_n	—	—	—	2.0	—	μs
		CK-CK-OUT			—	1.0	—	
		CK- \overline{MO}			—	2.8	—	
		E- ϕ_n			—	1.0	—	
		R- ϕ_n			—	2.0	—	
	"L" Level	CK- ϕ_n	—	—	—	1.4	—	
		CK-CK-OUT			—	0.7	—	
		CK- \overline{MO}			—	2.1	—	
		E- ϕ_n			—	1.2	—	
		\overline{R} - ϕ_n			—	1.0	—	
		R- \overline{MO}			—	2.0	—	
	Maximum Clock Frequency		f_{max}	—	—	—	250	
Set Up Time CK, CW / CCW		t_{set-up}	—	—	—	0.1	—	μs
Hold Time CK, CW / CCW		t_{hold}	—	—	—	0.1	—	
Minimum Clock Pulse Width		$t_w(CK)$	—	—	—	1.0	—	
Minimum Reset Pulse Width		$t_w(R)$	—	—	—	1.0	—	
Maximum Clock Rise Time		$t_r(CK)$	—	—	—	10	—	

TIMING CHART 3 PHASES METHOD

1 PHASE EXCITATION CW

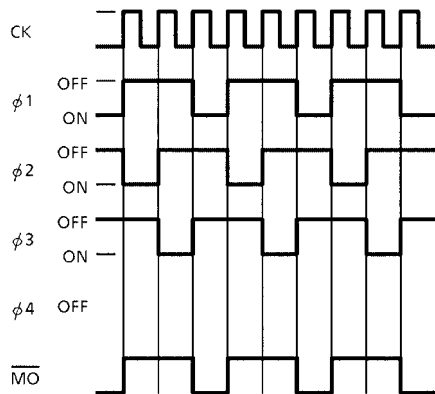

1 PHASE EXCITATION CCW

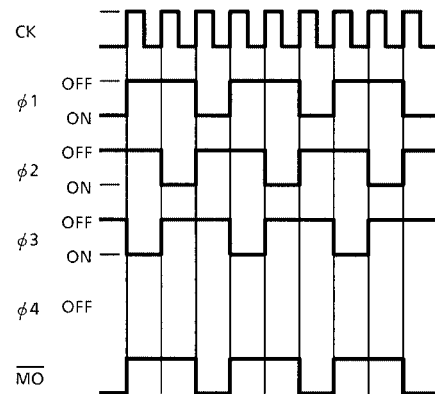

2 PHASE EXCITATION CW

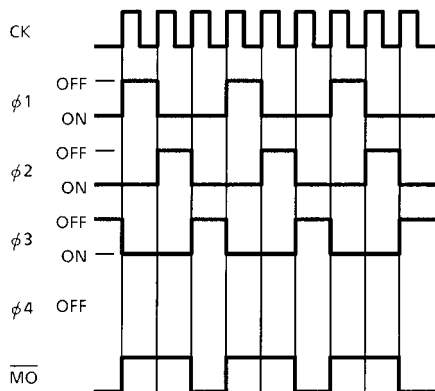

2 PHASE EXCITATION CCW

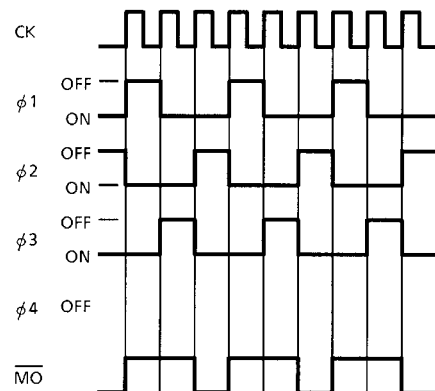

1-2 PHASE EXCITATION CW

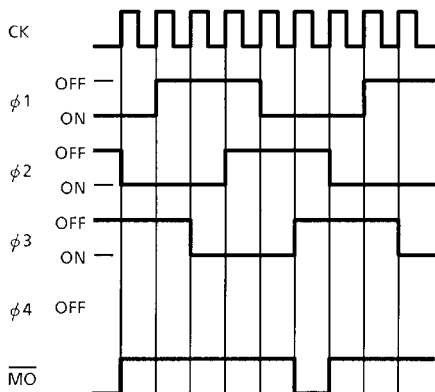

1-2 PHASE EXCITATION CCW

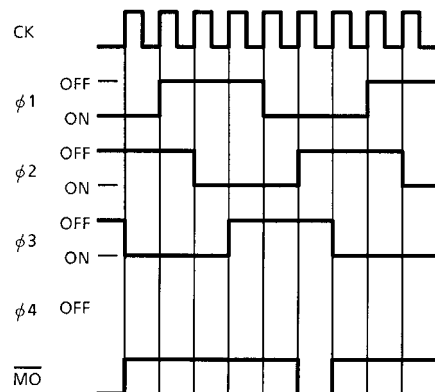

4 PHASES METHOD

1 PHASE EXCITATION CW

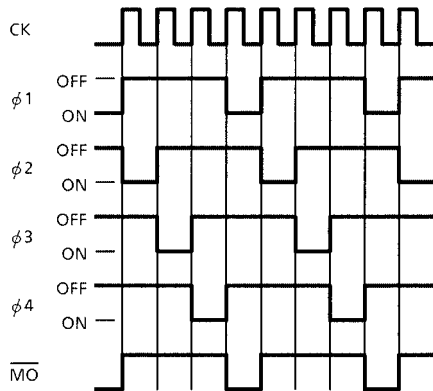

1 PHASE EXCITATION CCW

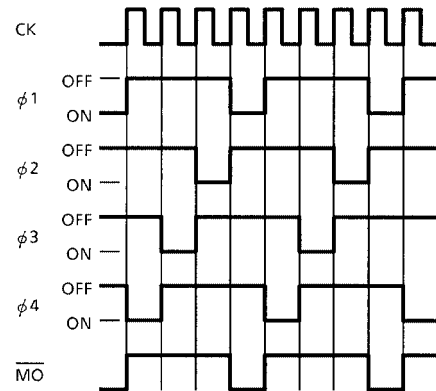

2 PHASE EXCITATION CW

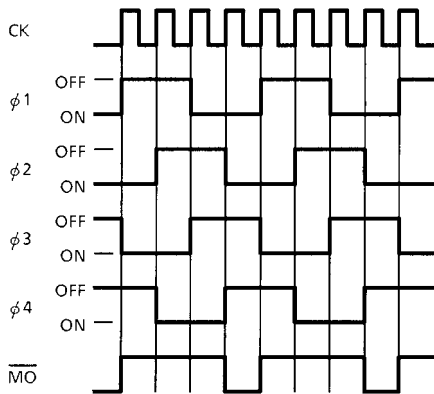

2 PHASE EXCITATION CCW

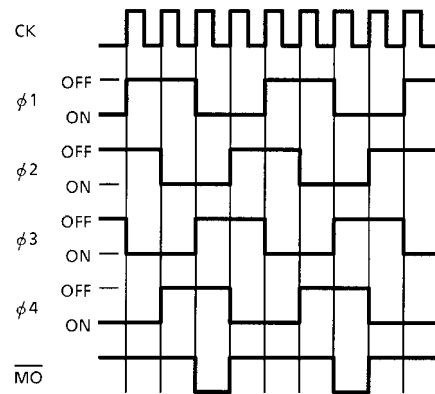

1-2 PHASE EXCITATION CW

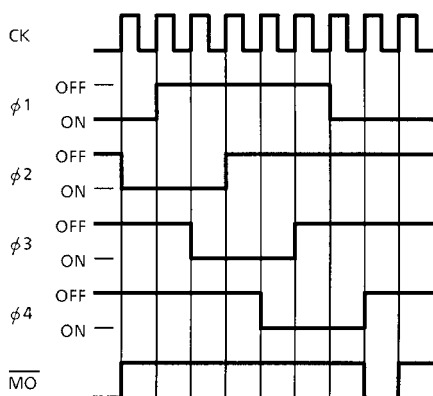

1-2 PHASE EXCITATION CCW

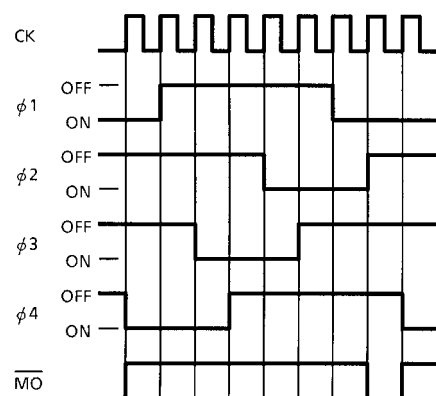

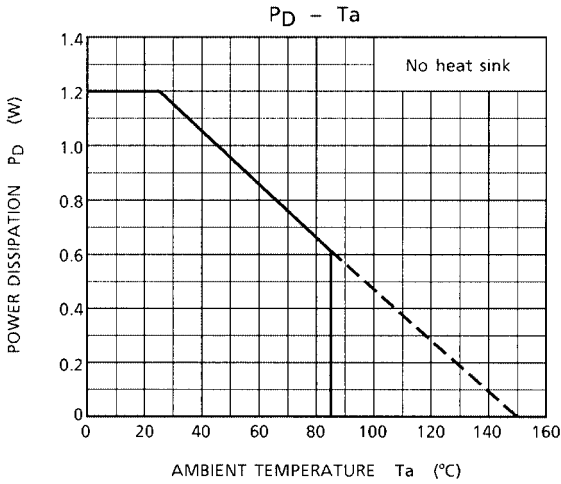
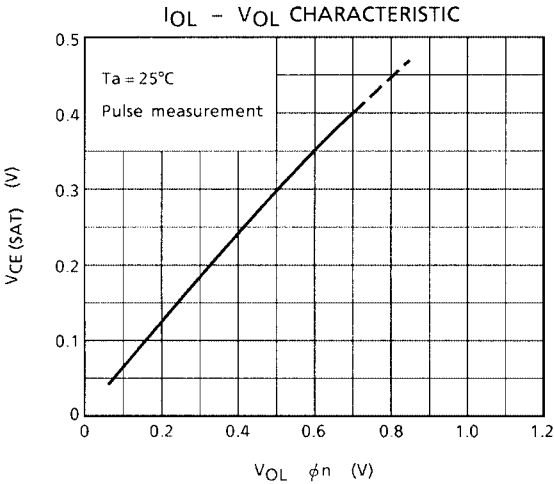

APPLICATION CIRCUIT 1 (TA8415P + TD62308BP 4 phase stepping motor driver circuit)

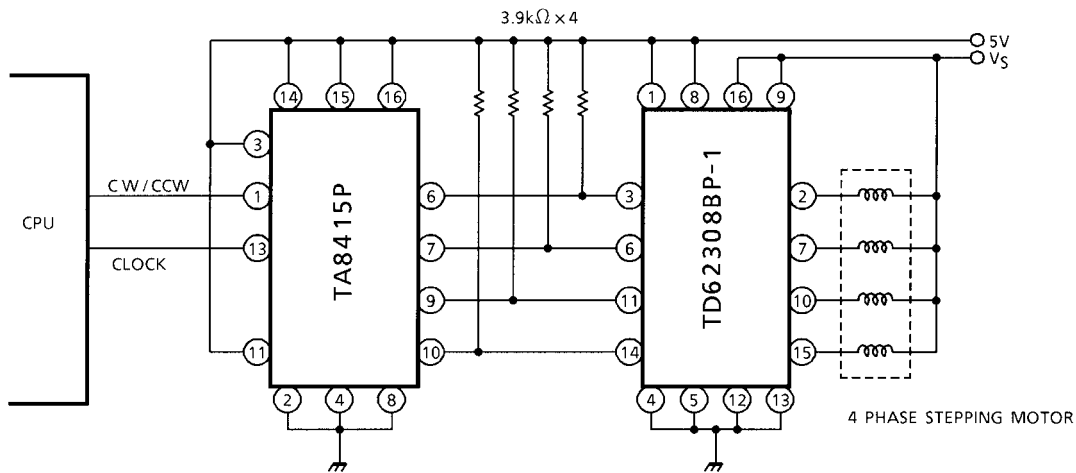

APPLICATION CIRCUIT 2 (TA8415P + TD62553S + MP4001 high efficiency stepping motor driver circuit)

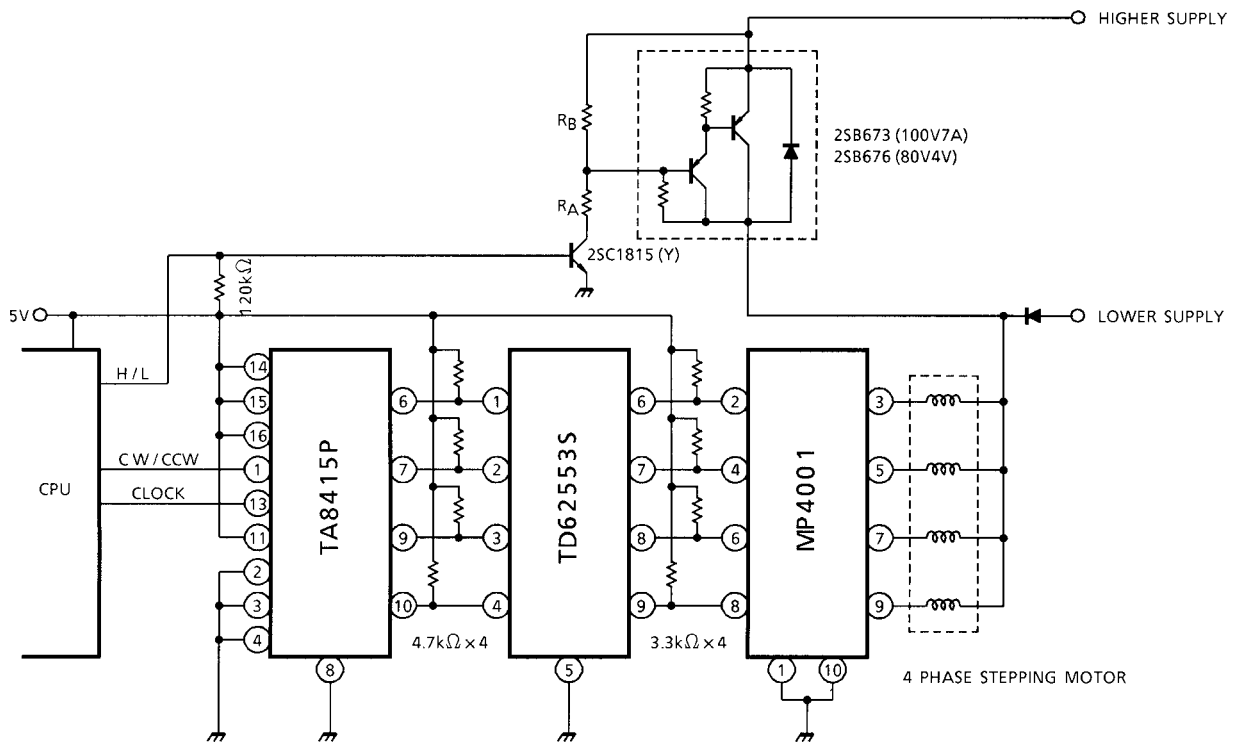

APPLICATION CIRCUIT 3 4 phase motor 1-2 phase excitation drive I.

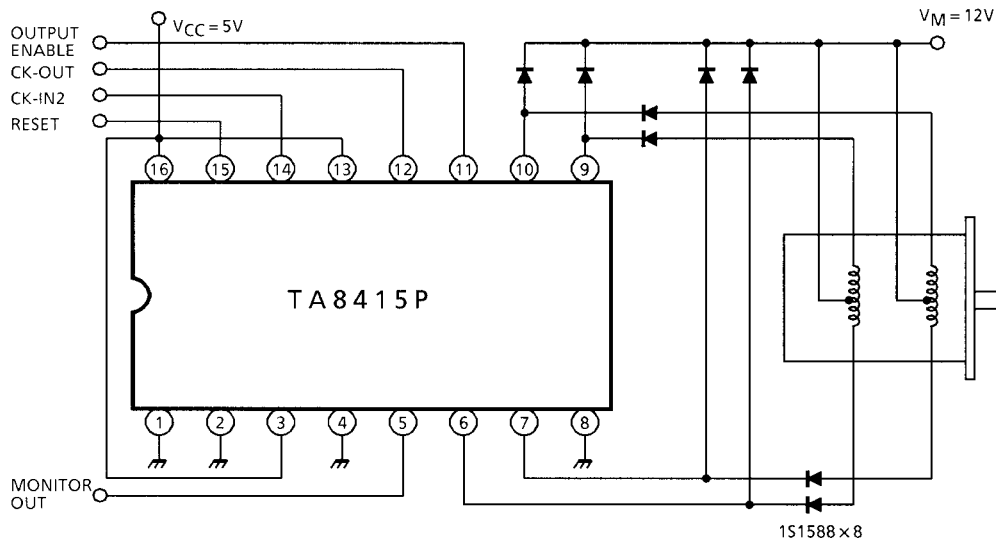

APPLICATION CIRCUIT 4 4 phase motor 1-2 phase excitation drive II.

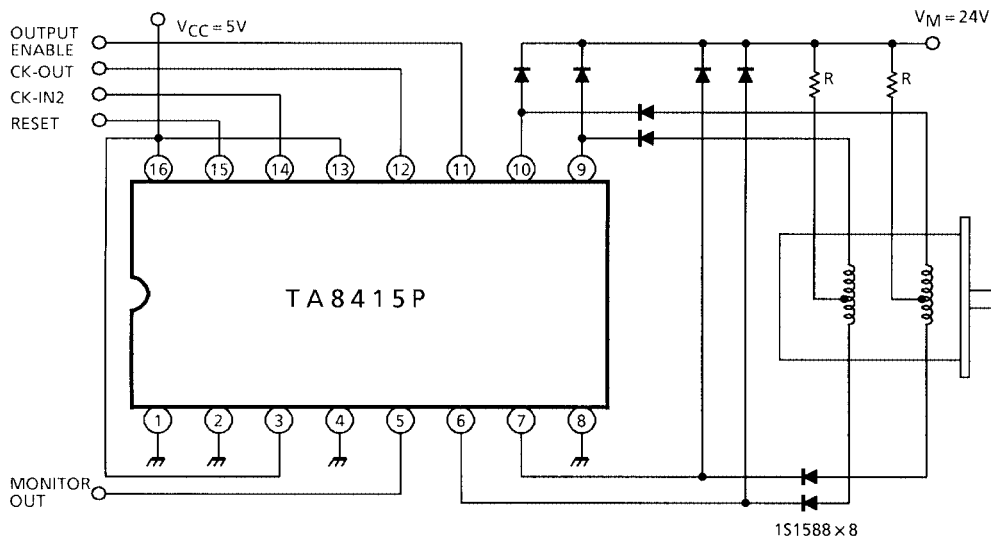

Note: Utmost care is necessary in the design of the output line, power supply and GND line since IC may be destroyed due to short-circuit between outputs, air contamination fault, or fault by improper grounding.

PACKAGE DIMENSIONS

DIP16-P-300-2.54A

Unit: mm

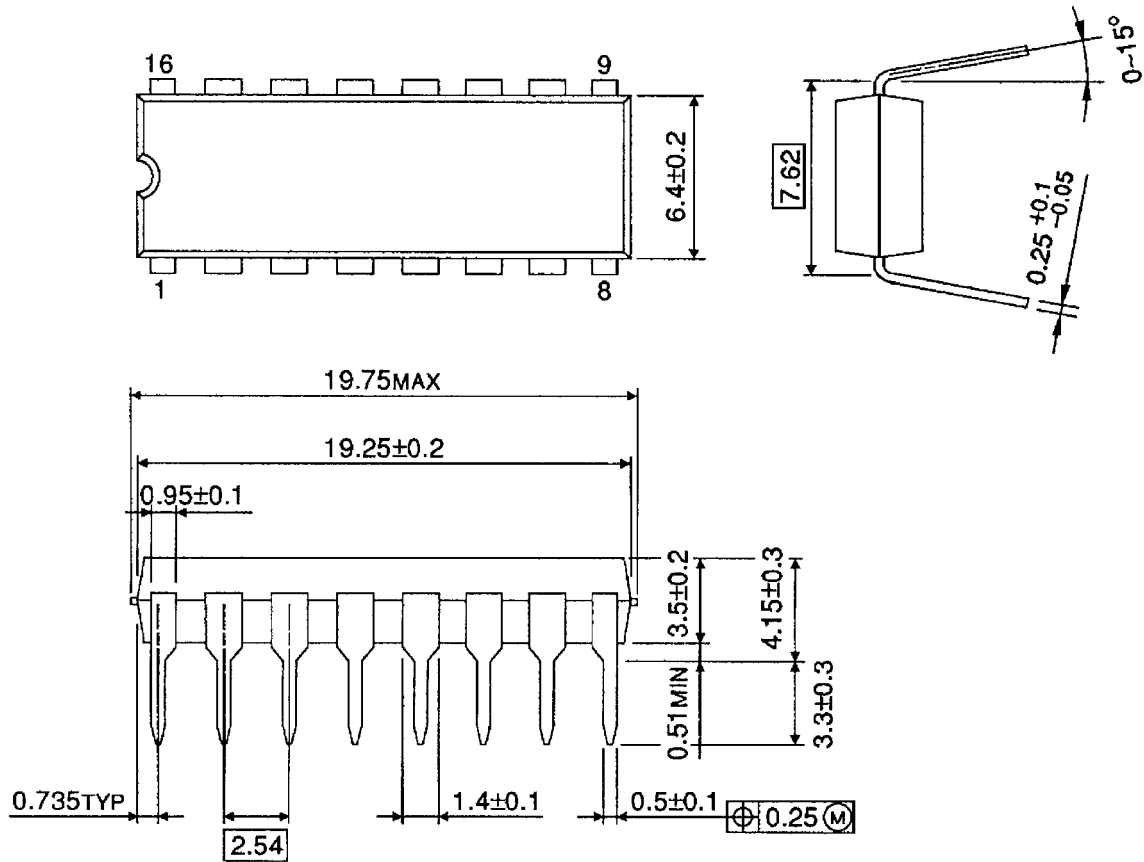

Weight: 1.11 g (Typ.)

RESTRICTIONS ON PRODUCT USE

030619EBA

- The information contained herein is subject to change without notice.
- The information contained herein is presented only as a guide for the applications of our products. No responsibility is assumed by TOSHIBA for any infringements of patents or other rights of the third parties which may result from its use. No license is granted by implication or otherwise under any patent or patent rights of TOSHIBA or others.
- TOSHIBA is continually working to improve the quality and reliability of its products. Nevertheless, semiconductor devices in general can malfunction or fail due to their inherent electrical sensitivity and vulnerability to physical stress. It is the responsibility of the buyer, when utilizing TOSHIBA products, to comply with the standards of safety in making a safe design for the entire system, and to avoid situations in which a malfunction or failure of such TOSHIBA products could cause loss of human life, bodily injury or damage to property.
In developing your designs, please ensure that TOSHIBA products are used within specified operating ranges as set forth in the most recent TOSHIBA products specifications. Also, please keep in mind the precautions and conditions set forth in the "Handling Guide for Semiconductor Devices," or "TOSHIBA Semiconductor Reliability Handbook" etc..
- The TOSHIBA products listed in this document are intended for usage in general electronics applications (computer, personal equipment, office equipment, measuring equipment, industrial robotics, domestic appliances, etc.). These TOSHIBA products are neither intended nor warranted for usage in equipment that requires extraordinarily high quality and/or reliability or a malfunction or failure of which may cause loss of human life or bodily injury ("Unintended Usage"). Unintended Usage include atomic energy control instruments, airplane or spaceship instruments, transportation instruments, traffic signal instruments, combustion control instruments, medical instruments, all types of safety devices, etc.. Unintended Usage of TOSHIBA products listed in this document shall be made at the customer's own risk.
- The products described in this document are subject to the foreign exchange and foreign trade laws.
- TOSHIBA products should not be embedded to the downstream products which are prohibited to be produced and sold, under any law and regulations.